

VIEW9 (1 : 20)

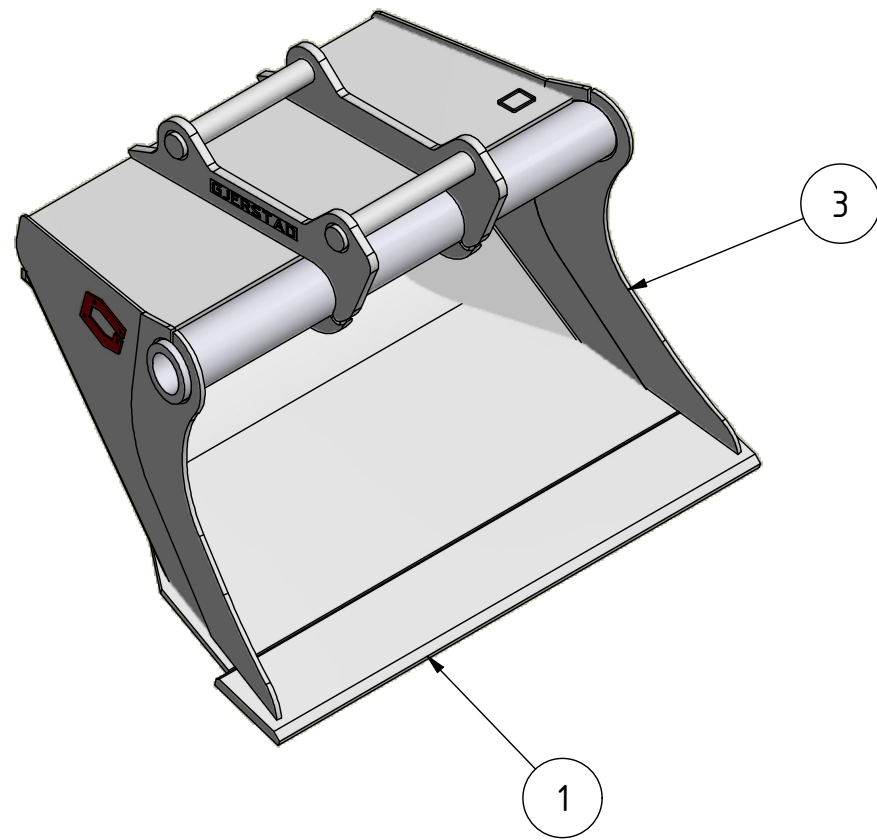

VIEW6 (1 : 15)

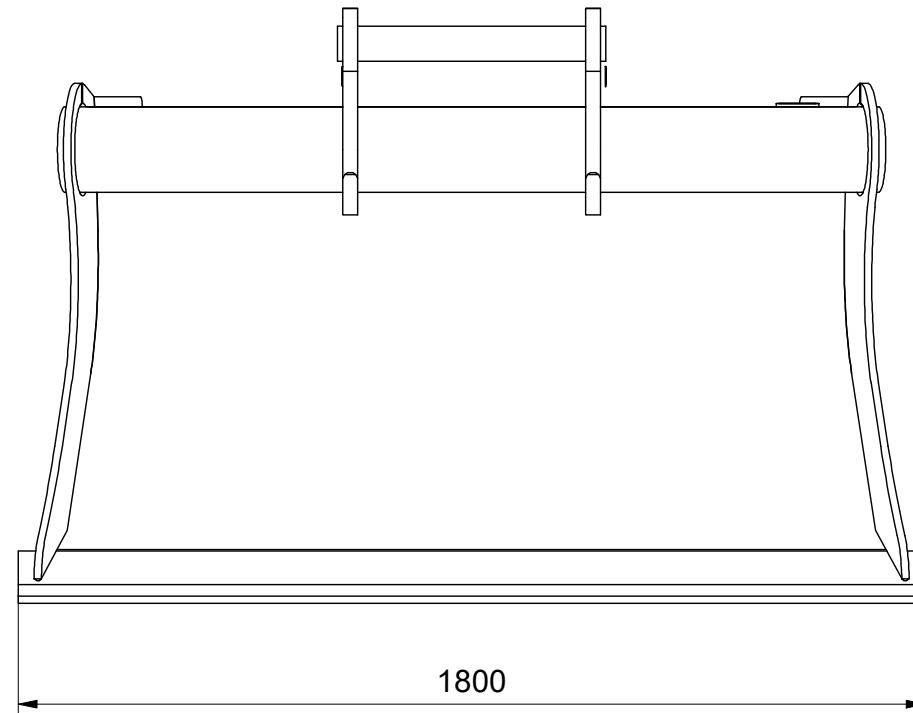
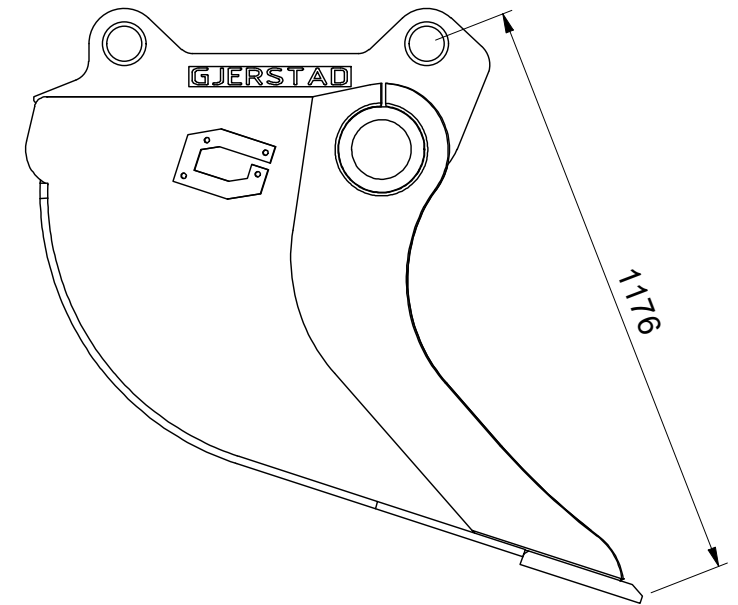

VIEW8 (1 : 20)

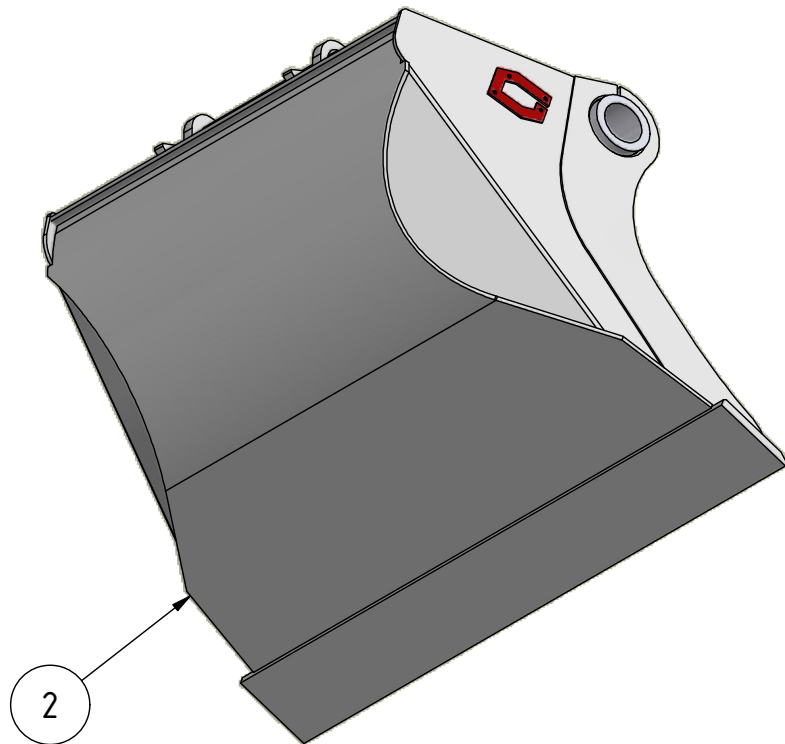

Recommended machine weight:

SPECIFICATION			
POS	TITLE	MATERIAL	DESCRIPTION
1.	FRONT EDGE	30x250x1800mm	HB500
2.	BOTTOM PLATE	15mm	HB450
3.	SIDE MEMBER	15mm	HB500
4.			
5.			
6.			

This drawing and design is our property, and NOT allowed copied or used without our permission. Any misuse can lead to prosecution and/or liability for compensation according to law.

SURFACE TREATMENT ACCORDING TO: P17.01

UNLESS OTHERWISE SPECIFIED DIMENSIONS ARE IN mm

SHEET 1 OF 3

Scale: A3

Projection:

Date: 13.12.2020

Draw.: PL

Contr.:

G HD GRADING BUCKET 1100L SAE S70
STRAIGHT FRONT 1800mm

Draw.no.: **GE7322**

Total weight: 868 kg

Revision: -

Gjerstad Products AS
Gjerstadveien 373, N-4993 sundebbru
www.gjerstad.com